



**DMP**

No.15, Wugong 5th Rd., Xinzhuang Dist.,  
New Taipei City 24890, Taiwan (R.O.C.)

# **RoBoard Module RM-G211**

Manual V1.01

The Heart of Robotics

Nov 2012

DMP Electronics Inc

ROBoard

## • Copyright

The information in this manual is subject to change without notice for continuous improvement in the product. All rights are reserved. The manufacturer assumes no responsibility for any inaccuracies that may be contained in this document. And makes no commitment to update or to keep current the information contained in this manual.

No part of this manual may be reproduced, copied, translated or transmitted, in whole or in part, in any form or by any means without the prior written permission of the DMP Electronics Inc.

©Copyright 2012 DMP Electronics Inc.

Manual No. RM-G211-01 Ver.1.01 • Nov, 2012

## • Trademarks Acknowledgment

Other brand names or product names appearing in this document are the properties and registered trademarks of their respective owners. All names mentioned herewith are served for identification purpose only.

# Table Of Contents

|  |   |
|--|---|
| Introduction.....                                  | 4 |
| 1.1 Packing List .....                             | 4 |
| 1.2 Product Description .....                      | 5 |
| 1.3 Specifications.....                            | 5 |
| 1.4 I <sup>2</sup> C Address .....                 | 5 |
| 1.5 Board Dimension .....                          | 6 |
| Introduction.....                                  | 7 |
| 2.1 Board Outline.....                             | 7 |
| 2.2 Connectors & Jumpers Summary.....              | 8 |
| 2.3 Pin Assignments.....                           | 8 |
| <b>J1: I<sup>2</sup>C connector (Top)</b> .....    | 8 |
| <b>J2: I<sup>2</sup>C connector (Bottom)</b> ..... | 8 |
| Introduction.....                                  | 9 |
| Sample and development code .....                  | 9 |

# Chapter 1

## Introduction

### 1.1 Packing List

| Product Name   | Package                |
|--|------------------------|
| RM-G211  | RoBoard Module RM-G211 |
|  A green printed circuit board (PCB) module. It features a white multi-pin connector on the left side, a black 6-pin header on the right side, and two gold-plated through-hole pins. Various electronic components like a microcontroller and resistors are visible on the board. |                        |
| Cable-RM-1   | 1x6 pin Cable x 1      |
|  A flat ribbon cable with a black 6-pin header on one end and a white multi-pin connector on the other. The cable is coiled and set against a light green background.  |                        |

## 1.2 Product Description

The RoBoard Module RM-G211 is an 8 channel 12 bit Analog to Digital module (AD7998), simply and all done through I2C interface, the dimension of it is wee as 20 x 20 mm.

## 1.3 Specifications

|                   |   |
|-------------------|---|
|                   | RM-G211 Analog to Digital module            |
| Analog to Digital | 8 Channel 12 Bit (AD7998)                   |
| Interface         | I <sup>2</sup> C                            |
| Default Address   | 0x21  |
| Connectors        | 1.25mm 6-pin wafer for I <sup>2</sup> C x 2 |
| Power Input       | DC-in 5V                                    |
| Dimension         | 20mm X 20mm                                 |
| Weight            | 2.5g  |

## 1.4 I<sup>2</sup>C Address

- Default : 0x21

## 1.5 Board Dimension

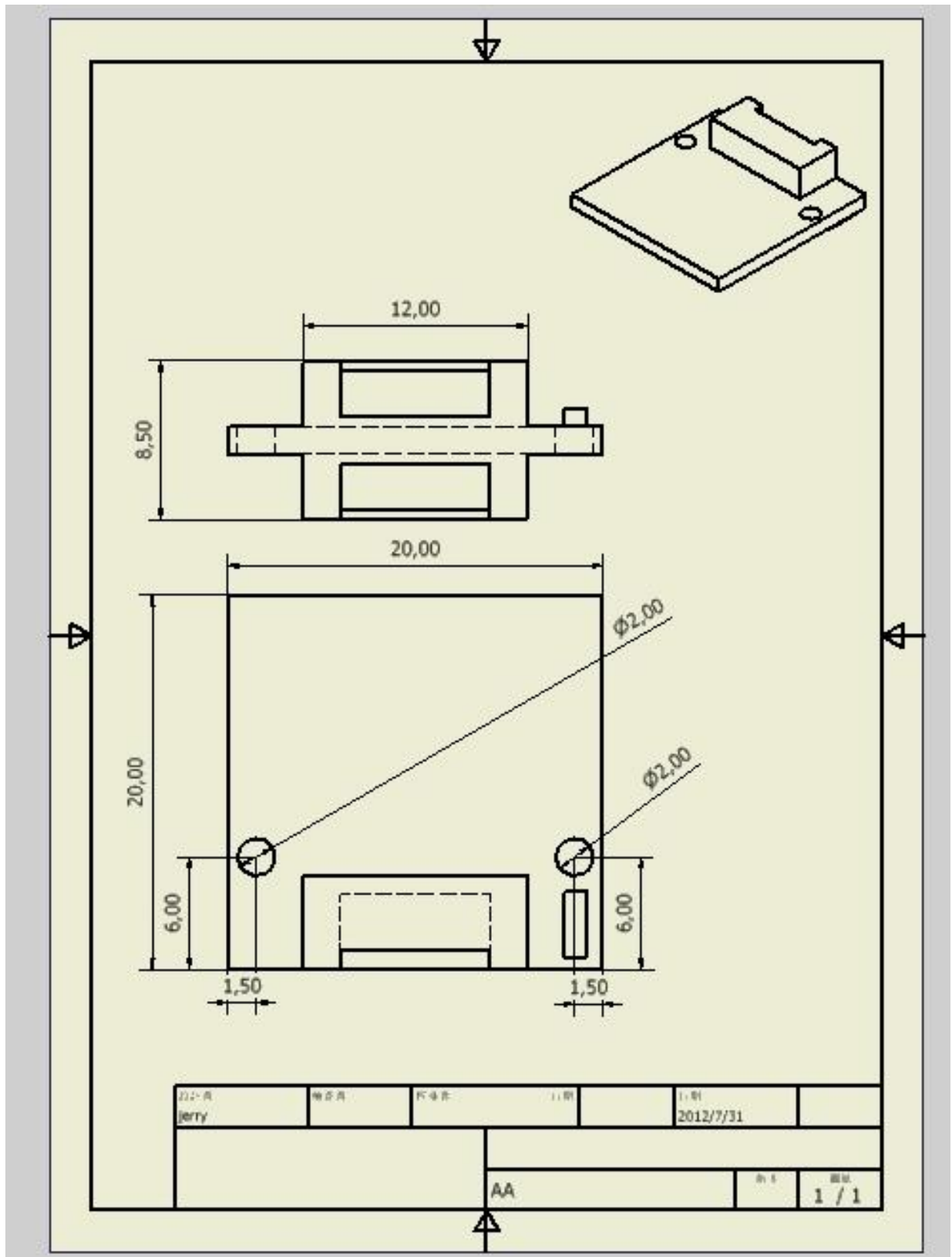

# Chapter 2

## Introduction

### 2.1 Board Outline

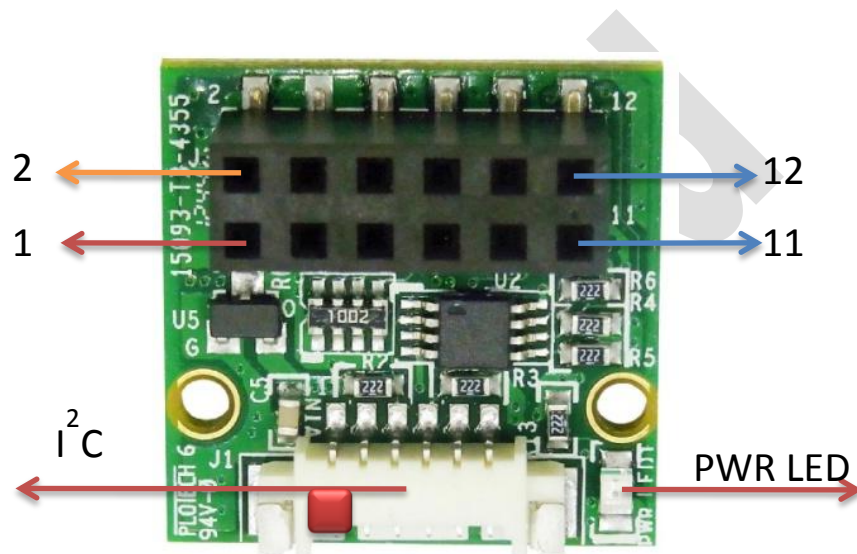

ADC Pin Assignment

|    |      |     |     |      |      |      |      |      |      |      |      |
|----|------|-----|-----|------|------|------|------|------|------|------|------|
| 1  | 2    | 3   | 4   | 5    | 6    | 7    | 8    | 9    | 10   | 11   | 12   |
| 5V | 3.3V | GND | GND | VIN1 | VIN2 | VIN3 | VIN4 | VIN5 | VIN6 | VIN7 | VIN8 |

## 2.2 Connectors & Jumpers Summary

| Summary Table |                                     |                     |       |
|---------------|-------------------------------------|---------------------|-------|
|               | Description                         | Type of Connections | Pin   |
| J1            | I <sup>2</sup> C connector (Top)    | Wafer, 2.54mm,6x1   | 6-pin |
| J2            | I <sup>2</sup> C connector (Bottom) | Wafer, 2.54mm,6x1   | 6-pin |

## 2.3 Pin Assignments

### J1: I<sup>2</sup>C connector (Top)

| Pin # | Signal Name |
|-------|-------------|
| 1     | Vcc (Red)   |
| 2     | GND (Black) |
| 3     | SCL (Blue)  |
| 4     | SDA (Green) |
| 5     | X (White)   |
| 6     | X (Orange ) |

### J2: I<sup>2</sup>C connector (Bottom)

| Pin # | Signal Name |
|-------|-------------|
| 1     | Vcc (Red)   |
| 2     | GND (Black) |
| 3     | SCL (Blue)  |
| 4     | SDA (Green) |
| 5     | X (White)   |
| 6     | X (Orange ) |



# Chapter 3

## Introduction

### Sample and development code

The RM-G211 provides sample and development code.

Please download from official website: <http://www.roboard.com>

### Warranty

This product is warranted to be in good working order for a period of one year from the date of purchase. Should this product fail to be in good working order at any time during this period, we will, at our option, replace or repair it at no additional charge except as set forth in the following terms. This warranty does not apply to products damaged by misuse, modifications, accident or disaster. Vendor assumes no liability for any damages, lost profits, lost savings or any other incidental or consequential damage resulting from the use, misuse of, originality to use this product. Vendor will not be liable for any claim made by any other related party. Return authorization must be obtained from the vendor before returned merchandise will be accepted. Authorization can be obtained by calling or faxing the vendor and requesting a Return Merchandise Authorization (RMA) number. Returned goods should always be accompanied by a clear problem description.